



Server Technology

Quality Rack Power Solutions

Alternating Phase Power Distribution at the Data Center Rack PDU

White Paper STI-100-012
November 2013 - Updated August 2014

By Steve Hammond, Product Manager, Server Technology
Marc Cram, Director of OEM and Global Accounts

HEADQUARTERS - NORTH AMERICA

Server Technology, Inc.
1040 Sandhill Drive
Reno, NV 89521
United States
1.775.284.2000 Tel
1.775.284.2065 Fax
sales@servertech.com
www.servertech.com
www.servertechblog.com

Western Europe, Middle East and Africa

Server Technology
Fountain Court
2 Victoria Square
Victoria Street
St. Albans
AL1 3TF
United Kingdom
+44 (0) 1727 884676 Tel
+44 (0) 1727 220815 Fax
salesint@servertech.com

Central Europe, Eastern Europe and Russia

Niederlassung Deutschland
Server Technology LLC
42119 Wuppertal
Germany
Tel: + 49 202 693917 x 0
Fax: + 49 202 693917-10
salesint@servertech.com

APAC

Server Technology
Room 2301, 23/F, Future Plaza
111-113 How Ming Street, Kwun
Tong, Hong Kong
Direct line: +852 3916 2048
Fax Line: +852 3916 2002
salesint@servertech.com

Overview

The demand for more power in the computer cabinet has led many data centers to upgrade to three phase power distribution. Proper three phase power distribution has traditionally meant dividing power into multiple branches within the rack PDU (Power Distribution Unit). In this paper we will explore the advantages of a new, less common approach to PDU design by means of alternating each phase on a per-receptacle basis instead of a per branch basis.

Traditional Branch Power distribution – North America and Japan

The illustration below shows a typical wiring diagram for 208V, 30A Delta power distribution within a rack PDU. The input power is represented by X, Y, and Z along with a ground wire. A pair of powered lines (XY, YZ, or ZX) and a ground is used to provide 208VAC power for each branch. Proper PDU design dictates that one branch is used for each phased pair. This means that three branches are required to fully distribute the available 30A of power. An equal quantity of outlets is used on each branch. By dedicating a branch for each phased pair the end-user reduces the risk of overloading any single phase.

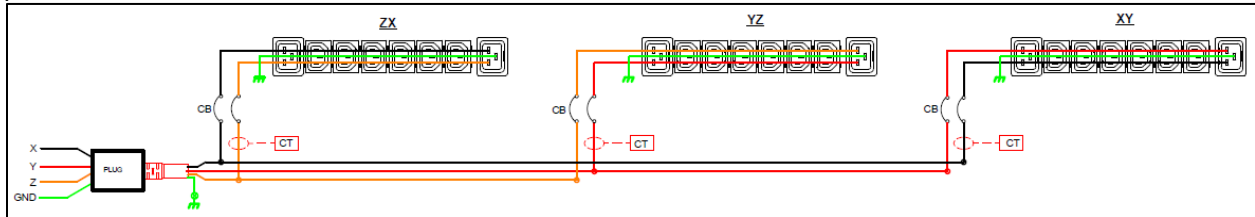

Basic Wiring illustration for a 208VAC, 3-Phase, 30A Delta PDU

Due to the maximum ratings of IEC 60320 C13 and C19 receptacles that comprise each branch, a 20A rated overcurrent protection device (usually a circuit breaker or fuse) is wired upstream. The protection device ensures that the receptacles cannot be damaged in an overcurrent situation. The illustration above uses “CB” to identify the two-pole breakers used to protect each branch.

Keep in mind that this example is for 30A distribution. Many newer data centers are moving to 60A service at the rack to support high density applications. Doubling the current effectively doubles the minimum number of branches within the PDU from three to six to fully distribute the power (see example below)

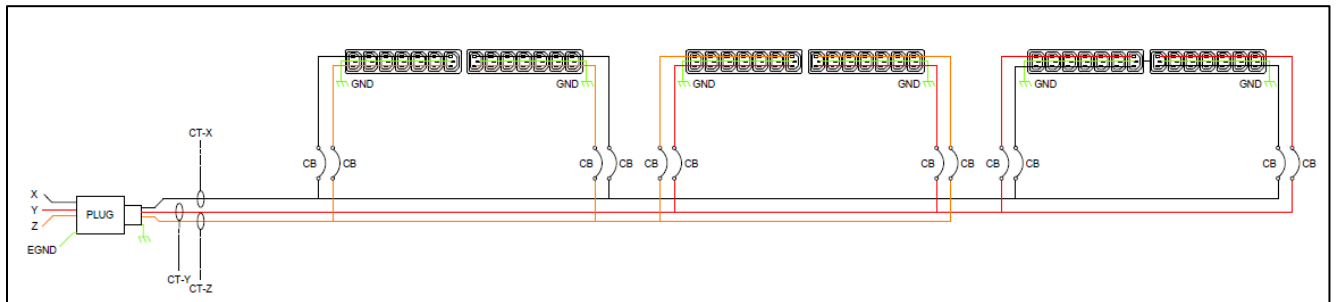

Wiring illustration for 208V, 3-Phase, 60A Delta PDU. Note that double the current means double the number of branches.

Traditional Branch Distribution for Three Phase Wye Power

Power distribution that includes a neutral wire is referred to as Wye distribution. Three phase Wye power is how we get 120VAC power in North America (found by taking 208VAC divided by $\sqrt{3}$). Wye distribution is also commonly found outside of North America. Instead of dividing the power into phased pairs as seen in the prior examples, each IEC receptacle gets a single phase, neutral and a ground wire. A common scenario would be to distribute 400V, 3-phase, 32A Wye power to the data center cabinet. When the 400V is wired line-to-neutral, then 230V is supplied to the outlet (400V divided by $\sqrt{3}$). Since the 32A power on each single phase exceeds the maximum rating of the IEC C13 and C19 receptacles, the PDU manufacturer is forced to divide the power between two branches for each single phase. Once again, a 20A overcurrent protection device is wired upstream of the outlets for protection.

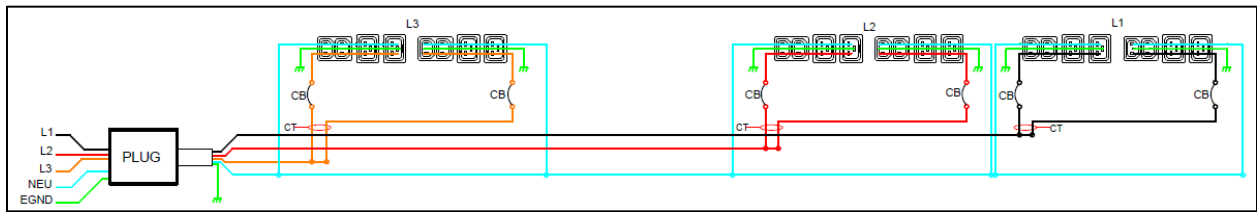

Example of the internal wiring used in a 400V, 3-Phase 32A Wye PDU

Properly dividing the phased power into equal branches is of great importance. Careful planning of the IT load can help distribute the load equally across each branch. This is referred to as load balancing. Equalizing the load on all three phases provides the greatest efficiency in power distribution as well as reduces heat generation in the IT loads of the data center rack. Equalizing the loads in a three phase Wye system also minimizes the current that exits the rack on the Neutral wire. This translates into power that is charged for but is not utilized by the IT gear. Much has been written about data center load balancing in other papers, but the easiest and most important place to employ proper load balancing is at the rack PDU. . Much has been written about data center load balancing in other papers, but the first place to employ proper load balancing is at the rack PDU.



Proper labeling on the front of the PDU as well as multiple displays aid the end-user in determining the wiring of each branch as well as the current draw of each phase

Alternating Phase – A New Look at 3-Phase Power Distribution

The principles of 3-Phase power are not always well understood by the installer, whose only task is to power up the equipment being installed in the computer rack. Load balancing (matching current draw on each phase) is critical in these applications for multiple reasons:

- 1) If the three phases are not balanced, heat is generated resulting in higher cooling costs.
- 2) Unbalanced loads lead to inefficiency and higher power bills.
- 3) High loads on a single phase means greater chance of tripping either a PDU or upstream breaker, and losing power at the rack.

Good practice in the data center is to install rack mounted equipment so that the current draw is similar on each branch. This is relatively easy if the rack is filled with only one type of device. Unfortunately this is often not the case. Mixed devices such as switches, storage devices, blade servers and different brands and types of 1U/2U/3U servers can create a crazy mesh of power cables in the back of the rack. This can potentially inhibit airflow and add to the heat problems mentioned above.

The issues above are compounded by the move to higher density racks that demand more kilowatts of power. Higher power distribution at 60A and 100A force even more complex PDUs with six, nine, and even twelve branches. The power draw still must be evenly distributed across these branches.

A solution to these issues is to use an alternating phase PDU. These specially designed PDUs alternate the phased power on a per-outlet basis instead of a per-branch basis. An example of these products can be seen below:



Outlets are grouped together up and down the PDU instead of broken up into individual branches.

Power wiring becomes simpler with this type of PDU since power cords do not need to be stretched across the length of the vertical PDU to reach separate branches. Plugging into a different phase only means moving the cord several inches to the next available receptacle. Shorter power cords from the server to the PDU can now be used thus cleaning up the back of the rack cabling. Several benefits come from this:

- 1) Shorter power cords from the server to the PDU can now be used, thus cleaning up the back of the rack cabling.
- 2) Shorter cords result in lower cable resistance, with less power dissipated in the power cords.
- 3) Assembling the rack becomes a much simpler exercise, reducing assembly time and reducing the chance for error.
- 4) Shorter cords mean less mass, making them less likely to come unplugged during transport of the assembled rack

PDU with Traditional 3-Phase Branch Distribution



PDU with Alternating Phase Power Distribution

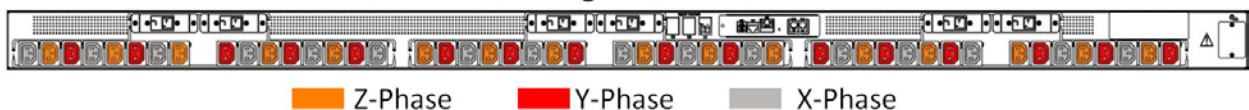

Alt phase vs. a traditional PDU

Traditional PDU

Alternating Phase PDU

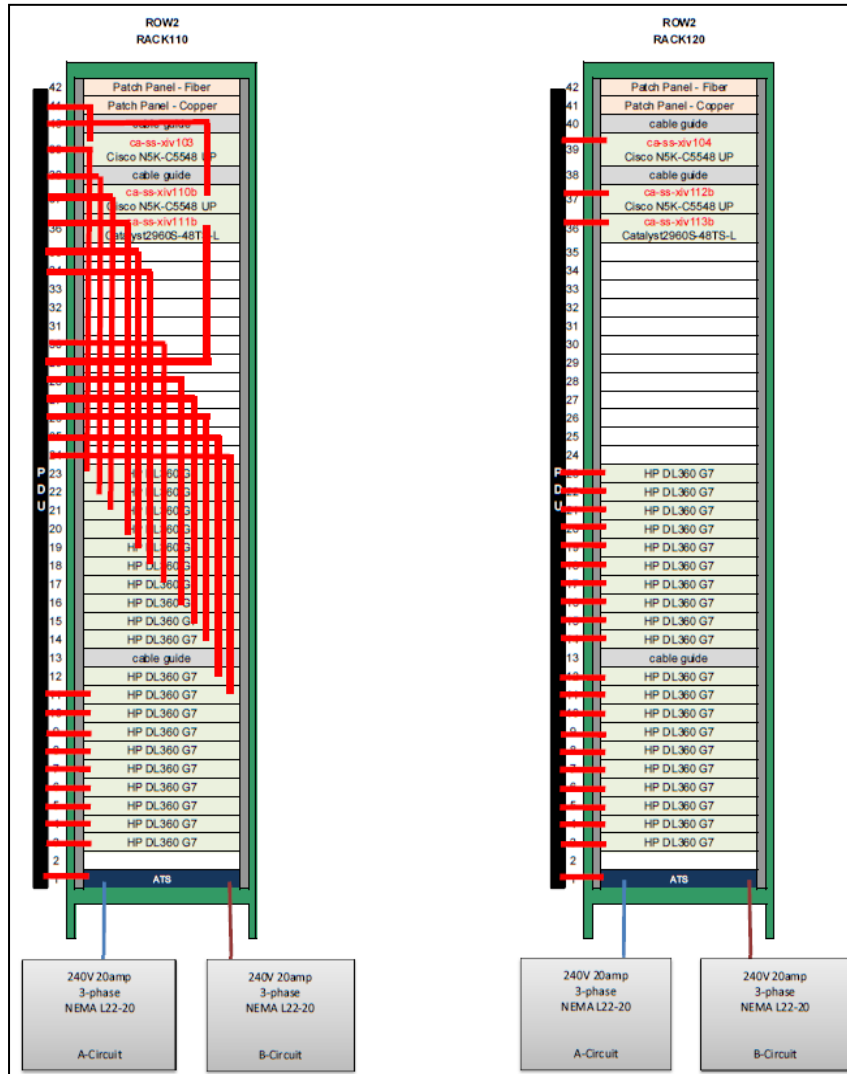

Cabinet on the left has a traditional PDU while cabinet on the right uses an alternating phase PDU

Alternating phase PDUs are also a great choice for Basic PDUs where there is no current measurement or display on the unit to assist with load balancing. Installers can plug in servers from the bottom to top of the rack with less risk of blowing a breaker since there are no dedicated branches across the length of the PDU.

Server Technology has patent pending unique method of distributing the alternating phase power to each outlet. Instead of using wires, our products use a multi-layer circuit board to separate the phases. Each outlet contacts a different trace within the board to distribute the proper phased voltage. This helps to reduce heat build-up in the PDU, lessens the human error during manufacturing and finally creates a cleaner design to reduce the physical size of the product.

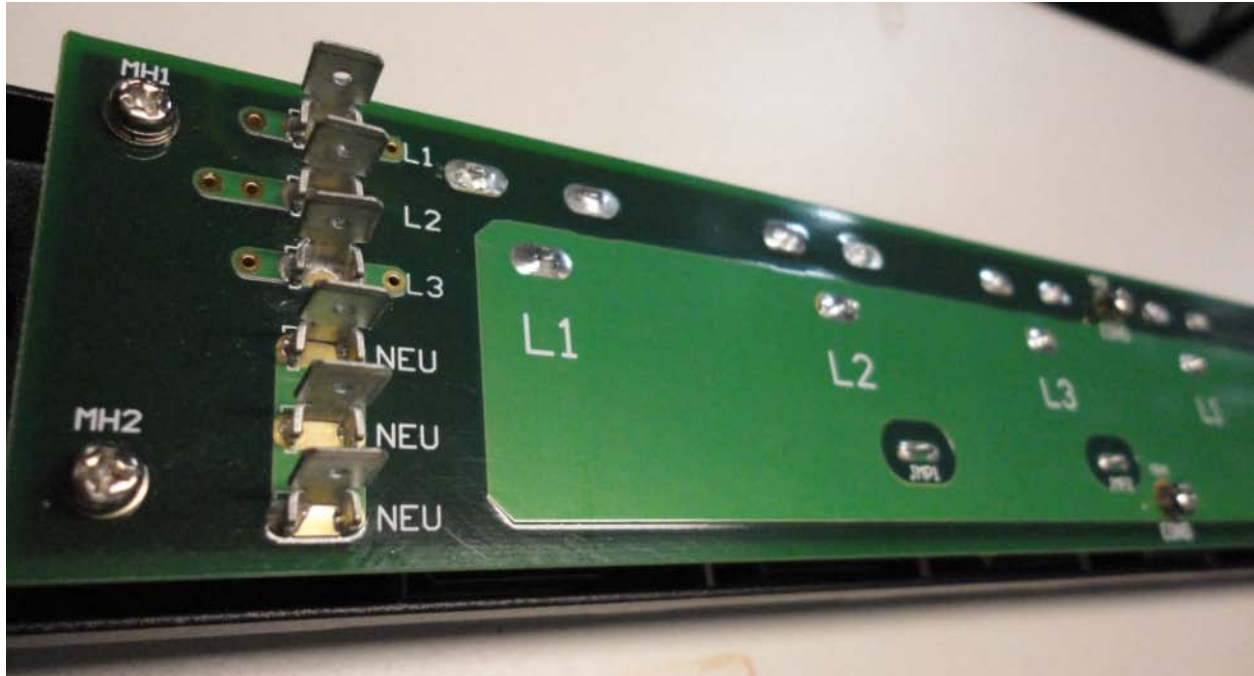

Example of a multi-layer power distribution board used in an alternating phase PDU

Summary

Three-phase power distribution at the rack level traditionally meant that power was divided into separate branches. Load balancing and cabling of these older PDU designs can be difficult. Power distribution units implementing alternating phased power on a per-receptacle basis provide tangible benefits in the form of simplified cabling, better airflow, better load balancing and greater efficiencies, thus lowering the operational expenses of the datacenter.